

- SuperATV recommends (2) people when installing Doors.
- Make sure door handles are unlocked before installing.
- Do not discard packaging until product has been successfully installed.
- Discard any remaining hardware.
- This item is not returnable if the protective film has been removed.
- Test fit to the cage to confirm fitment before removing film.
- Driver side installation shown in illustrations.

Door Cleaning:

- Do not use Rain-X[®], Plexus[®] or any other protector, wax, or polish.
 - Do not use window cleaning fluids (Windex, 409, etc) or any solvents (gasoline, denatured alcohol, acetone, etc).
 - Never use abrasive cleaners, abrasive pads, or gritty cloths.
 - Never use razor blades, scrapers, squeegees, brushes, etc.
1. Thoroughly rinse Doors to float off dirt and mud.
 2. Using a soft cloth, or microfiber cloth, clean Doors with warm water and a gentle detergent. Baby shampoo, rubbing alcohol, or hand washing soap can also be used.
 3. To prevent water spots, use a chamois to blot Doors dry.

Liability Statement

SuperATV's[®] products are designed to best fit user's ATV/UTV under stock conditions. Adding, modifying, or fabricating any factory or aftermarket parts will void any warranty provided by SuperATV[®] and is not recommended. SuperATV's[®] products could interfere with other aftermarket accessories. If user has aftermarket products on machine, contact SuperATV[®] to verify that they will work together.

Although SuperATV[®] has thousands of satisfied customers, user should be aware that installing lift kits, long travel, or suspension kits, tires, etc. will change the ride of machine and may increase maintenance and part wear. Operating any off-road machine while, or after, consuming alcohol and/or drugs increases risk of bodily harm or death. No warranty or representation is made as to this product's ability to protect user from severe injury or death. SuperATV[®] urges operators and occupants to wear a helmet and appropriate riding gear at all times.

By purchasing and installing SuperATV[®] products, user agrees that should damages occur, SuperATV[®] will not be held responsible for loss of time, use, labor fees, replacement parts, or freight charges. SuperATV[®], nor any 3rd party, will not be held responsible for any direct, indirect, incidental, special, or consequential damages that result from any product purchased from SuperATV[®]. The total liability of seller to user for all damages, losses, and causes of action, if any, shall not exceed the total purchase price paid for the product that gave rise to the claim.

SuperATV[®] will warranty only parts provided by SuperATV[®]. Any damage or problems with OEM housings, bearings, seals, or other manufacturers' products will not be covered by SuperATV[®]. SuperATV[®] parts and products are not warranted if item was not installed properly, misused, or modified.

Installing, adding, modifying, or fabricating any factory or aftermarket product to your ATV/UTV may violate certain local, state, and federal laws. Be advised that laws vary depending on town, city, county, state, etc. Use of certain products on public streets, roads, or highways may be in violation law. The Buyer is solely and exclusively legally and personally responsible for any violation of the law by the installation or use of the product. You must abide by all local, state, and federal laws, including but not limited to vehicle safety, traffic laws, and ordinances. It is your responsibility to know the laws and how they apply to you.

The Buyer is responsible to fully understand the capability and limitations of his/her vehicle according to manufacturer specifications, warnings and instructions and agrees to hold SuperATV[®] harmless from any damage resulting from failure to adhere to such specifications, warnings and/ or instructions. The Buyer is also responsible to obey all applicable federal, state, and local laws and ordinances when operating his/her vehicle while using this product, and the Buyer agrees to hold SuperATV[®] harmless from any violation thereof.

Need help with your installation?



sales@superatv.com



www.superatv.com



1-855-743-3427



8:00am - 8:00pm EST M-Th
8:00am - 7:00pm EST Friday
9:00am - 2:00pm EST Saturday

Read instructions and view illustrations before beginning.

Thank You

For Choosing



Kit Contents

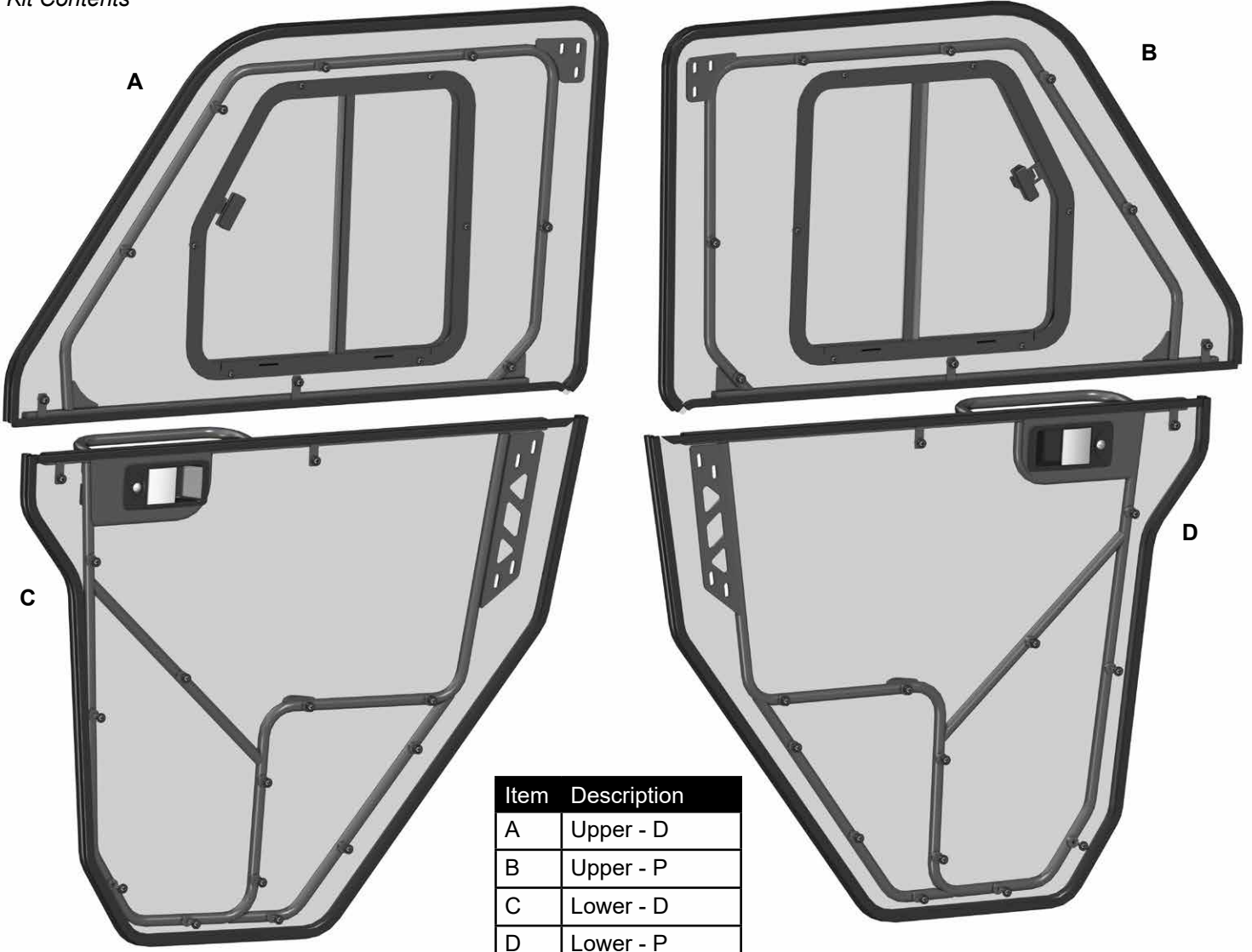

Item	Description
A	Upper - D
B	Upper - P
C	Lower - D
D	Lower - P



2x - Strut

*Foam

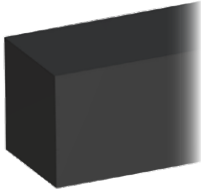

**Foam will not be installed unless there's an isolated area where Door will not completely Seal*

(kit contents continued)

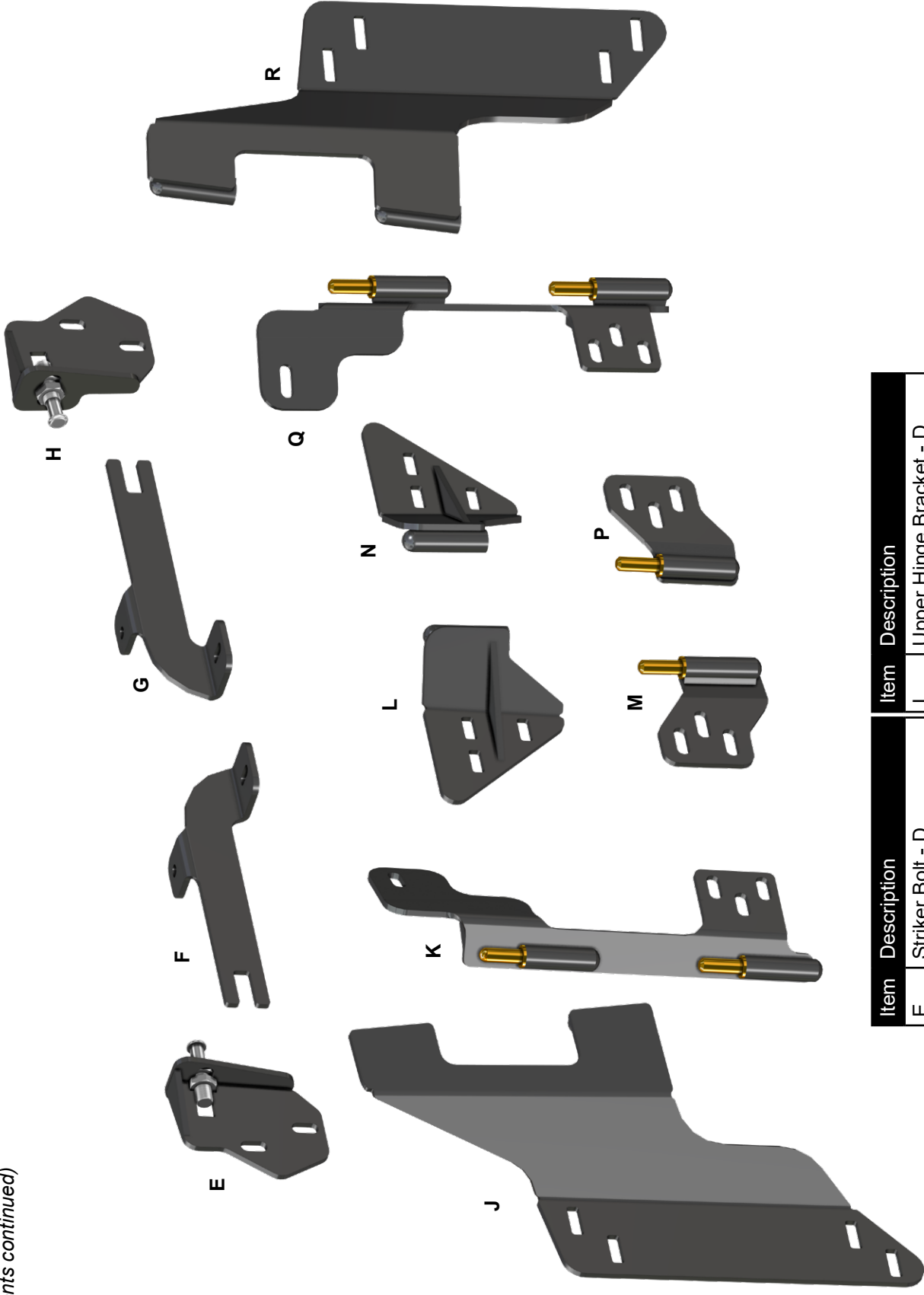

Item	Description	Item	Description
E	Striker Bolt - D	L	Upper Hinge Bracket - D
F	Strut Bracket - D	M	Upper Pin Bracket - D
G	Strut Bracket - P	N	Upper Hinge Bracket - P
H	Striker Bolt - P	P	Upper Pin Bracket - P
J	Lower Hinge Bracket - D	Q	Lower Pin Bracket - D
K	Lower Pin Bracket - D	R	Lower Hinge Bracket - P

remove components / hardware shown; do not discard

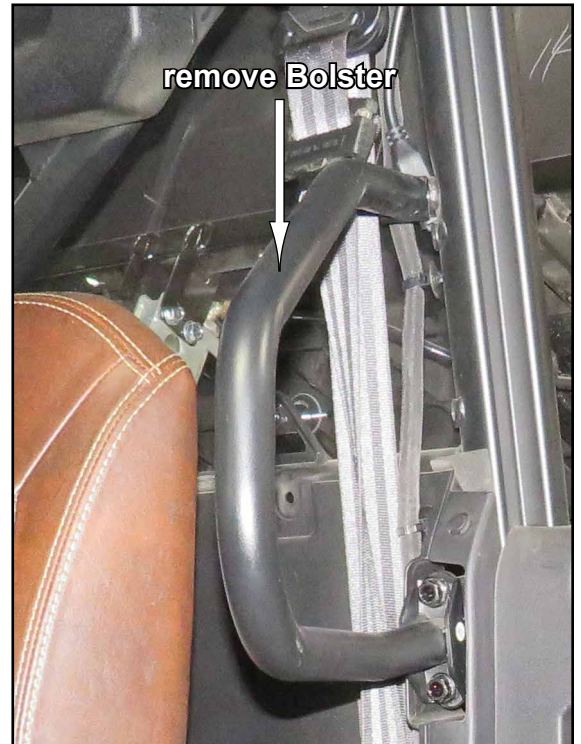

Bolsters and Nets will not be reinstalled

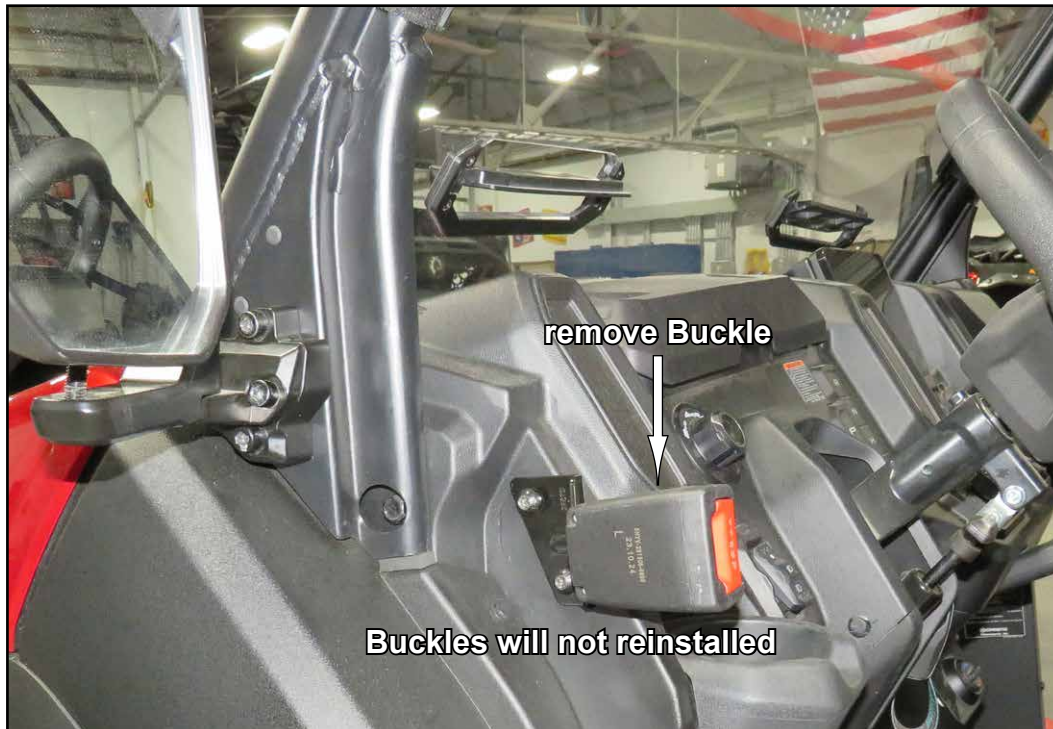

remove Upper Panel

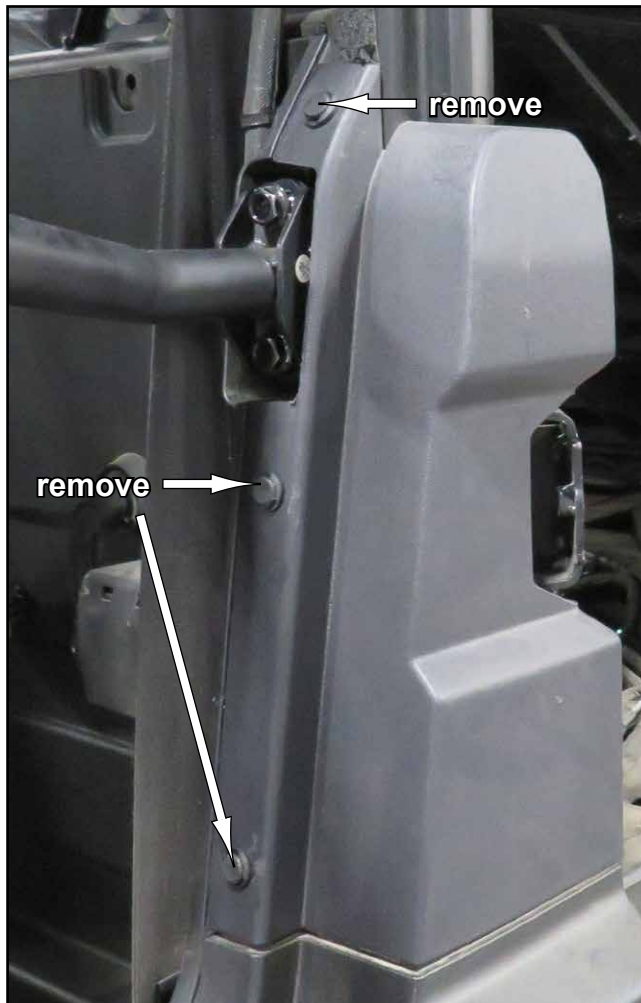

following procedure is for driver side only

remove components shown and pull back Rear Panel

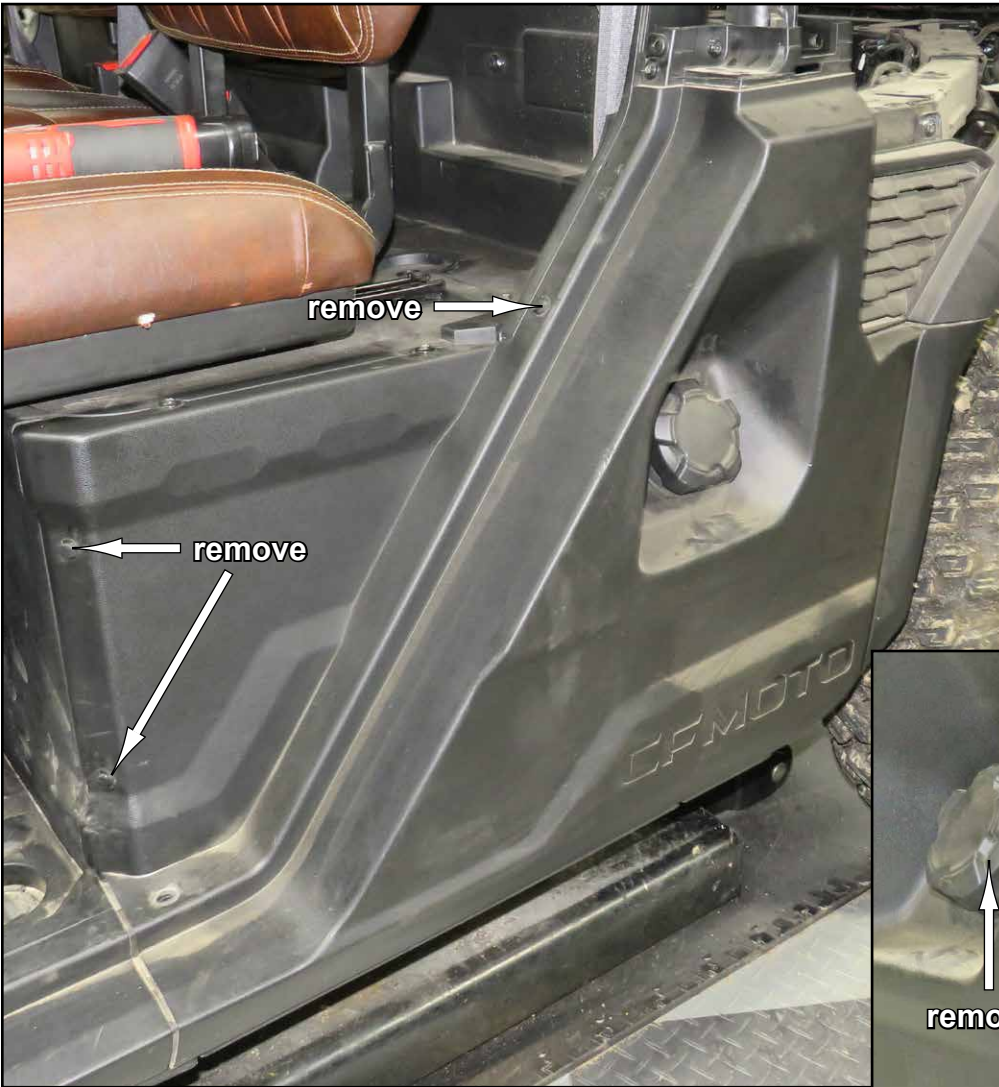

KEEP HARDWARE SNUG BUT NOT COMPLETELY TIGHT

- Install Striker Bolt - D (E) to machine with stock hardware.



- Join Lower - D (C) to Upper - D (A) with hardware shown; tighten.



4 each

M6 x 50mm

M6 Nut

KEEP HARDWARE SNUG BUT NOT COMPLETELY TIGHT

- Install Lower Hinge Bracket - D (J) and Upper Hinge Bracket - D (L) with hardware shown.

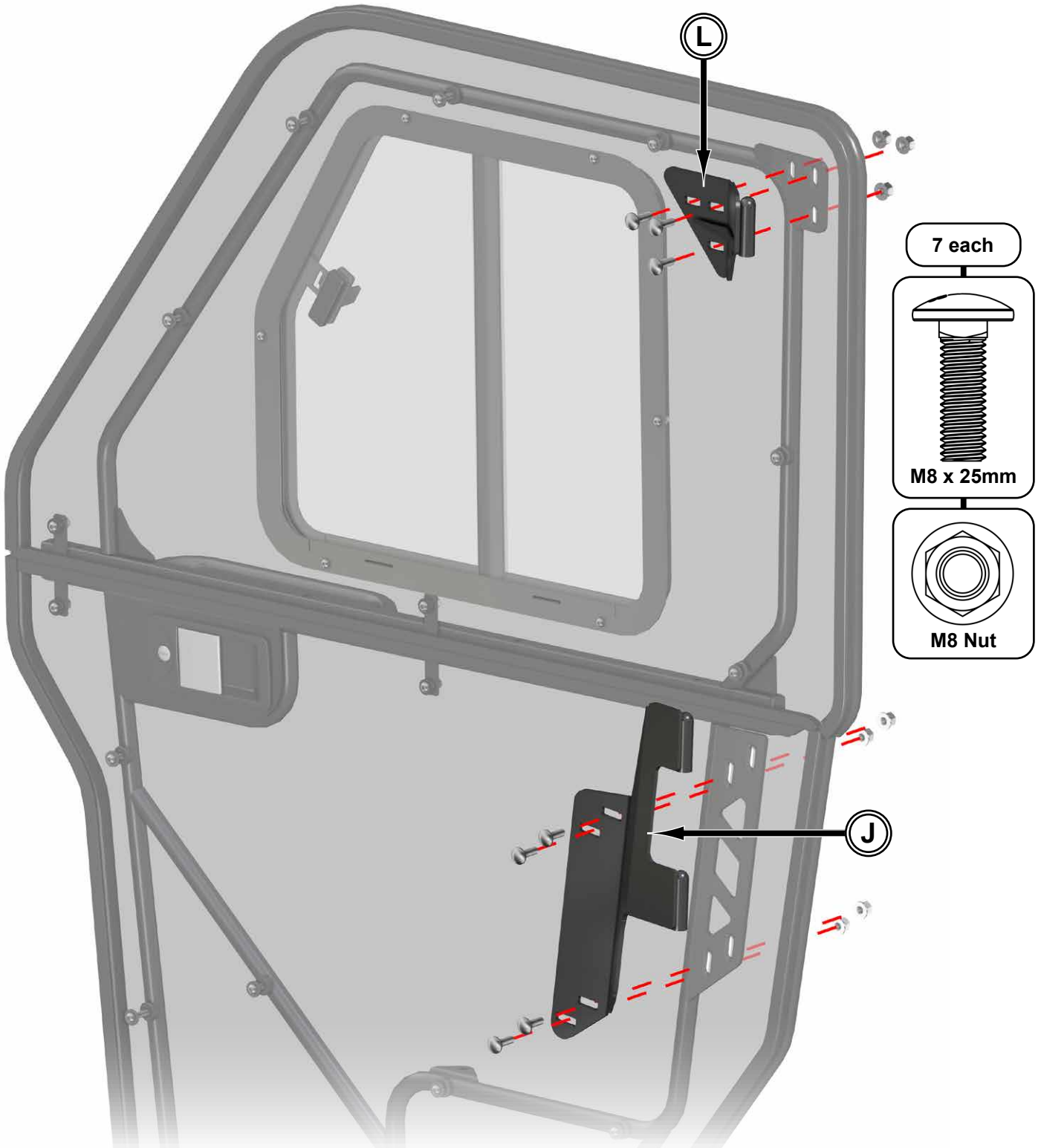

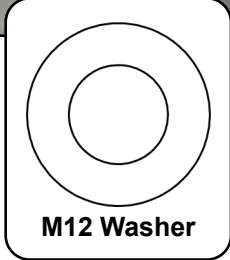
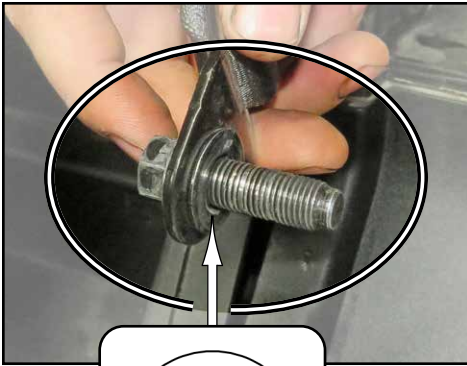

- Install Strut Bracket - D (F) and Washer to Seat Belt Hardware.



- Secure Strut Bracket - D (F) with stock hardware.
- Tighten **all** hardware.



When installing Strut Bracket - P (G) , Seat Belt Hardware can be accessed by removing Passenger Seat and Seat Panel.

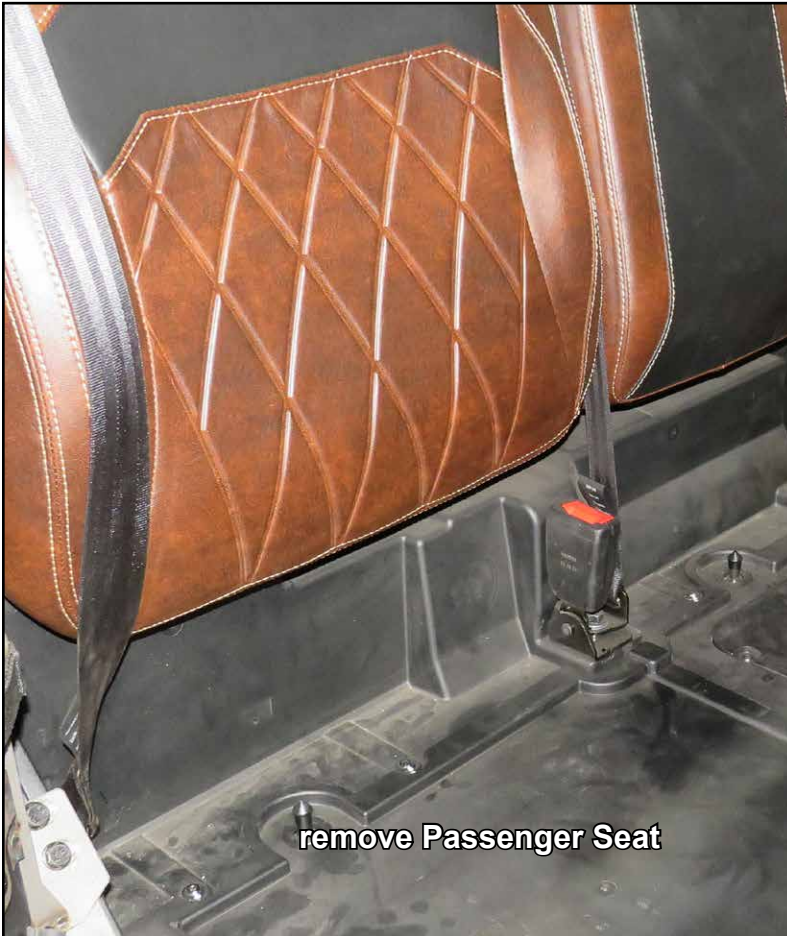

KEEP HARDWARE SNUG BUT NOT COMPLETELY TIGHT

- Secure assembly to machine with hardware shown.

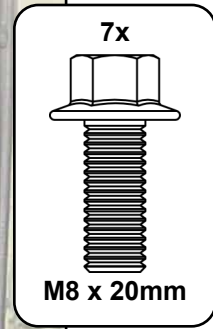

- Close Door and engage Latch.



- Align Door to machine and tighten **all** hardware completely.
- Use contours in stock plastic as a guide when aligning.



- Repeat steps for passenger side installation.
- Reinstall applicable stock components.

- Install Strut to Striker Bracket - D (F) and Lower - D (C) with hardware shown; tighten.
- Reinstall Front Seat.



- Repeat steps for passenger side installation.

- If user would like to install stock Mirrors to Doors, use included hardware shown.
- No holes in Doors or templates are provided. User must determine mounting location.

